

UNIT 8 GROUND FLOOR PLAN

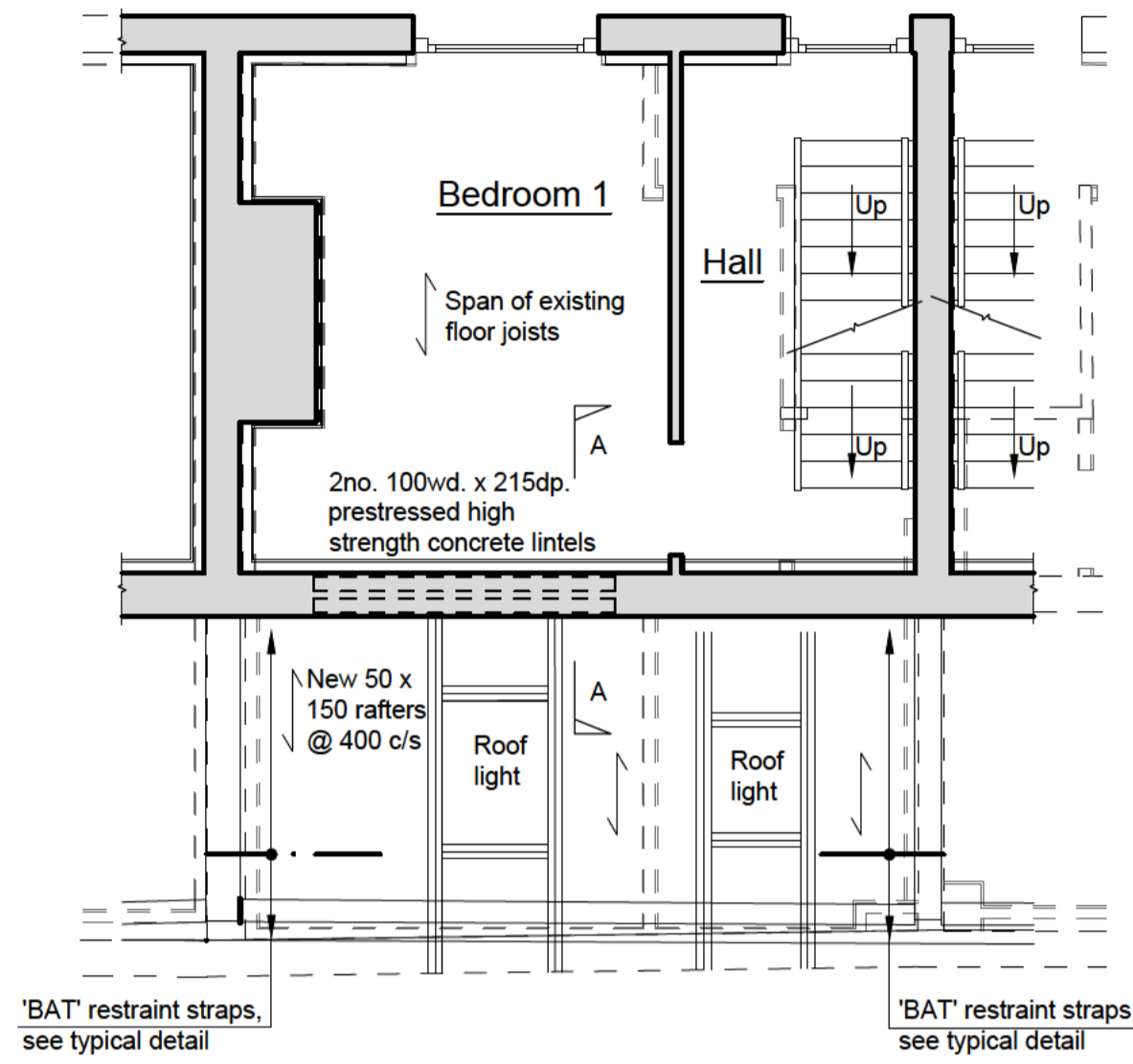

UNIT 8 FIRST FLOOR PLAN

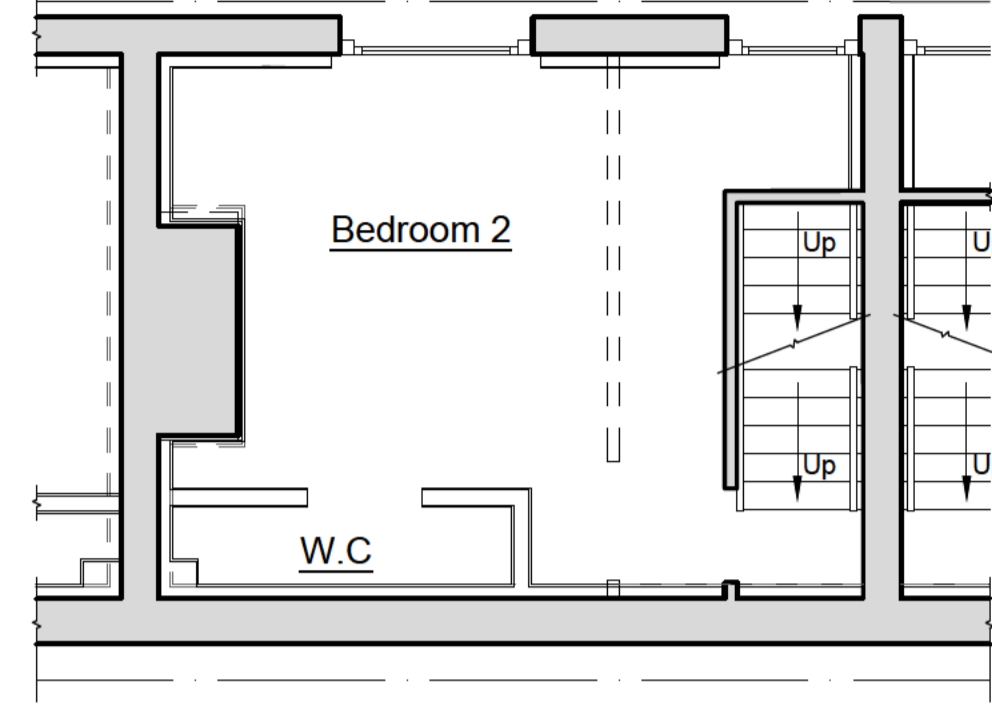

UNIT 8 SECOND FLOOR PLAN

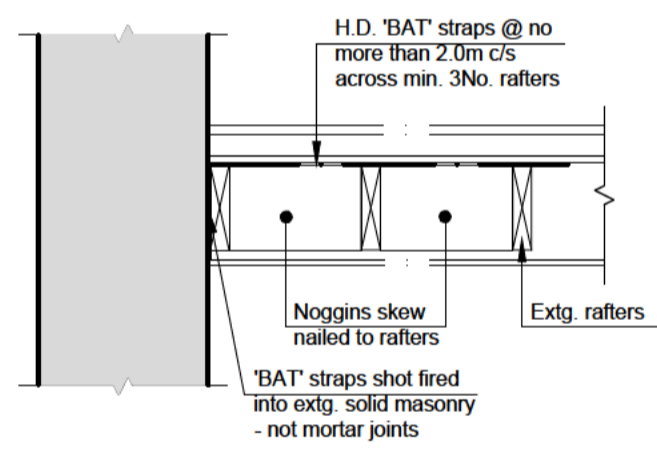

RESTRAINT DETAIL TO EXISTING WALL (1:20)

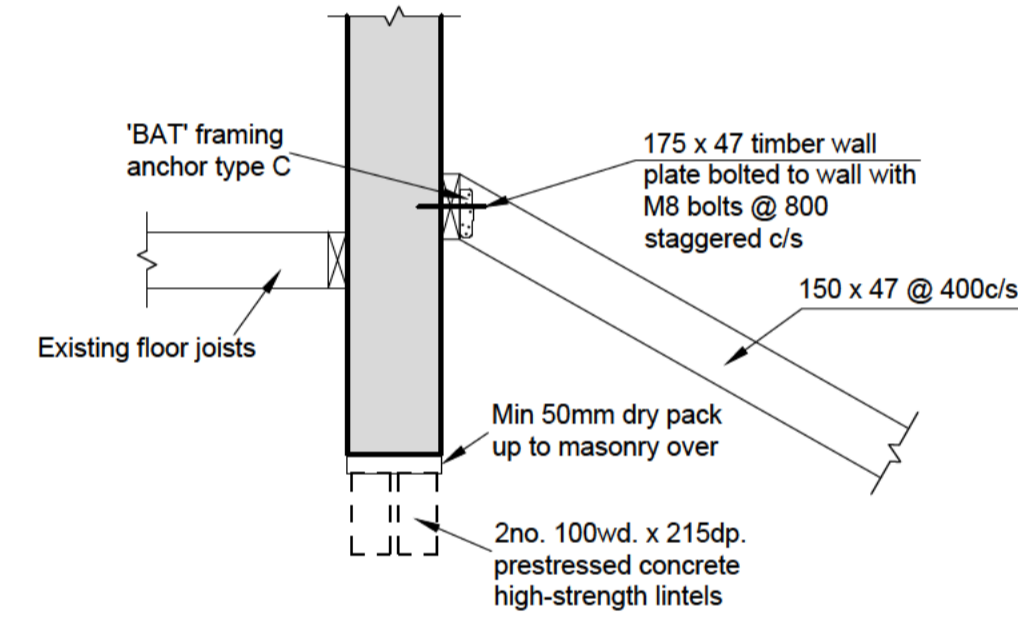

SECTION A - A (1:20)

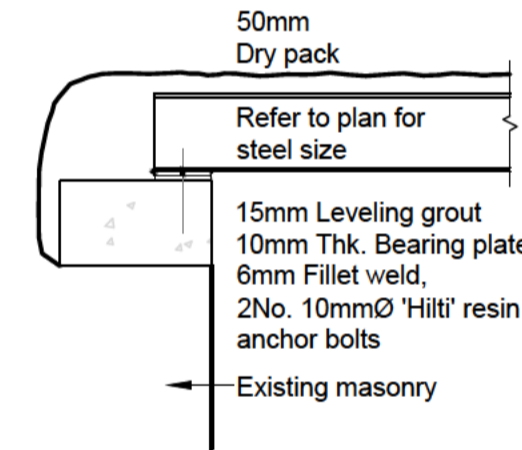

TYPICAL PADSTONE DETAIL (1:20)

**Specification Notes**

- This drawing to be read in conjunction with all relevant architectural & engineering drawings.
  - Refer to RGA standard specifications for any items not listed below.
  - For details of finishes, drainage, dpc, waterproofing, radon etc., refer to architect's details.
  - Where Radon protection is specified by the Architect, provide a continuous 150mm thick compacted radon layer beneath the lower slab comprising 20mm single sized, clean, sound non-friable angular crushed rock material free of contamination and deleterious material.
  - Assumed safe bearing capacity = 50 kN/m<sup>2</sup>.
  - All excavations to be viewed by the building control surveyor prior to blinding.
  - COSHH certificates to be provided for all products used.
- Construction Generally**
- Contractor is solely responsible for all temporary works. Any temporary works shown on our drawings are indicative only.
  - Care to be taken not to undermine existing adjacent structure during excavations for new foundation or ground floor slab. Some localised underpinning may be required.
  - Movement joints at no greater than 6m c/s to be provided in external blockwork outer leaf with slip ties, eg. Ancon PPS-250, at 225mm vertical centres. Locations to be agreed between architect and engineer.
  - Unless detailed otherwise, install restraint strapping in accordance with TGD Part 1 of the Building Byelaws;
    - Floor-to-wall strapping to be installed as per diagram 16(b) of TGD1
    - Roof-to-gable/eaves strapping to be as per diagram 17 of TGD1
- Loadings**
- Imposed floor loading = 1.5 kN/m<sup>2</sup>
  - Imposed roof loading = 0.75 kN/m<sup>2</sup>
- Concrete**
- Blinding & mass concrete to be grade C6/8 (nom. mix 1:4:8) unless noted otherwise.
  - Structural concrete to be grade C28/35 (opc) max aggregate size 20mm vibrated throughout.
  - Externally exposed structural concrete to be grade C28/35 XS-1, with max. w/c ratio of 0.5
- Steelwork**
- All mild steelwork to be min grade S355 to BS 5950, unless noted otherwise.
  - All stainless steelwork to be min grade 1.4401 (316) to SC1 P921: Structural Design of Stainless Steel, unless noted otherwise. Finish to architect's specification.
  - All structural members to have 1hr fire resistance throughout.
  - All paints to be by an approved supplier & if in any one scheme from different manufacturers they must be compatible. The contractor is to include & arrange for an independent inspector to periodically visit at works & site in order to ensure compliance to

- the specification & provide written reports back to the engineer on completion. In addition to the above, random dry film thickness readings on all areas of steel coated with intumescent paint should be recorded & on completion a copy of the manufacturer's fire certificate for the contract must be supplied.
  - All surfaces which are to be painted, oiled or otherwise treated shall be blast cleaned to Swedish standard Sa2½ & primed asap or within a max period of 4hrs.
  - After erection, & prior to on site painting, all steelwork to be washed clean of any saline contamination & allowed to dry before application.
  - Any damage to primer to be abraded & touched up on site (to original dry film thickness) after erection of steelwork & prior to application of intumescent coating.
  - Steelwork to be painted as follows:
 

**RG3) General steelwork & roof steelwork (no fire rating):**

    - 1 coat epoxy blast primer - 25 microns dry film thickness (travel coat).
    - 1 coat epoxy zinc phosphate primer - 100 microns dry film thickness (at works).
    - 2 coats epoxy MIO finish - 125 microns dry film thickness in total (on site).
- Timber**
- Structural timber to be strength class C16 (gs.m50: e.g. redwood/whitewood) pressure impregnated against rot, infestation & damp ingress.
  - Noggings to be installed in timber floors and flat roofs at the rate of:
    - No noggings for spans under 2.5m
    - 1 Noggings at mid-point for spans of 2.5 to 4.5m
    - 2 Noggings at 1/3 points for spans over 4.5m
- Timber Stairs**
- Timber stair construction to be in accordance with BS 585-1:1989.
- Glazing**
- Glazing to be designed in accordance with BS 6262:2005 and/or BS 5516:2004 and installed by FENSA or CERTASS approved contractors. Calculations & details, including connections to supporting structure, to be provided to engineer for SER certification to Building Control.
  - In order to satisfy SER Certification criteria, any Medium or High Risk Glazing (Typically but not limited to vertical glazing >8m<sup>2</sup>, horizontal/inclined glazing >2m<sup>2</sup> as well as glazing providing containment or guarding) will require project specific design verifications for the framing elements, glass panes and fixings when subjected to the loadings defined in BS6399 parts 1, 2 and 3. Design verification to be provided by the glazing supplier/fabricator.
  - Lintels above or below openings with sliding/folding sections have been design to limit post-installation live or creep deflection to span/500. The nominated supplier is to ensure that the glazing system is able to accommodate such deflection without adverse effect on the serviceability of the windows.

Rev	Date	Issued for Construction	Amendment	Initials
A	02/11/20	Issued for Construction		

1a Roudle Devonshire Place  
St. Helier Jersey JE2 3RD  
Telephone  
01534 879262  
Email  
admin@rga.co.je

Project  
Brooklyn Mews,  
La Route de St. Aubin,  
St. Helier.

Title  
Phase 3, Unit 8  
General Arrangements

Drawn	Scales	Sheet Size
	1:50, 1:20	A1
Checked	Drawing Status	Date
	Construction	28/10/20
Project No.	Drawing No.	Rev.
60163	60163/06	A